

METHOD TO CALCULATE THE LONGITUDINAL IMPEDANCE FROM A PARTIAL WAKEFIELD SIMULATION

N. Shipman^{*1,2}, G. Burt², J. Mitchell^{1,2} Lancaster University, Lancaster, UK
 R. Calaga, CERN, Geneva, Switzerland
¹also at CERN, Geneva, Switzerland
²also at Cockcroft Institute, Daresbury, UK

Abstract

When simulating modes with high Q-factors, the wake-field length necessary to calculate the impedance spectrum can often mean a computation time of several weeks or more. A method has been developed which enables the longitudinal impedance and Q-factors of multiple modes to be calculated from a partially decayed wakefield simulation. This paper presents an overview of the method along with preliminary, proof of principle, results showing that considerable simulation time can be saved whilst maintaining a good degree of accuracy.

INTRODUCTION

Calculating the impedance spectrum of an RF cavity is imperative for assessing whether or not the cavity is suitable for the proposed application [1] [2]. An eigenmode simulation can be used to calculate the mode impedances using the resulting R/Q and Q-factor values. When using this method of analysis, characterisation of each mode type is imperative. Due to this, time domain wakefield simulations are often used to provide comparative analysis of the cavity's impedance spectrum.

Computationally, wakefield simulations are intensive and hence result in simulations which take a large amount of time. This is specifically the case for high-Q modes where the wakefield must be simulated over a large distance before it decays enough for the impedance spectrum to converge.

This paper aims to assess the accuracy with which the fully converged impedance spectrum can be estimated, using the method here developed, from a partially decayed wakefield and the length of wakefield necessary to make such an estimation. For this purpose CST particle studio [3] was used to perform wakefield simulations of a simple pillbox cavity.

IMPEDANCE CALCULATION METHOD

For narrow band resonances the longitudinal wake-function, $G_{||}$, can be written as [4]:

$$G_{||}(t) = \sum_{n=1}^{\infty} \omega_n \left(\frac{R_s}{Q_n} \right) \cos(\omega_n t) \exp\left(-\frac{\omega_n t}{2Q_n}\right) \quad (1)$$

Where n is the mode number and ω_n , Q_n and $\frac{R_s}{Q_n}$ are the resonant angular frequency, quality factor and geometry factor respectively of mode n . For a charge travelling at

* nicholas.shipman@cern.ch

(almost) the speed of light $G_{||}(t) = 0$ for $t < 0$ and the longitudinal impedance, $Z_{||}(\omega)$, can be calculated by taking the Fourier-transform of the wake-function from zero to infinity:

$$Z_{||}(\omega) = \int_0^{\infty} G_{||}(\tau) \exp(-i\omega\tau) d\tau \quad (2)$$

Attempting to calculate the longitudinal impedance using Eq. (2) and a partially simulated wake-function, $G_{T||}(t)$, which has only been computed up until time T (and is taken to be zero for $t > T$) instead of $G_{||}(t)$, is equivalent to calculating:

$$\mathcal{Z}_{||}(\omega, T) = \int_0^T G_{||}(\tau) \exp(-i\omega\tau) d\tau \quad (3)$$

In general the truncated impedance spectrum, $\mathcal{Z}_{||}(\omega, T)$ will only equal $Z_{||}(\omega)$ when $T \gg \frac{Q_n}{\omega_n}$ otherwise the impedance spectrum will not have converged. However, if the integral in Eq. (3) is evaluated by substituting in Eq. (1) the following result is obtained:

$$\mathcal{Z}_{||}(\omega, T) = \sum_{n=1}^{\infty} \frac{A}{B + \omega_n^2/B} \cdot C \quad (4)$$

$$C = \left(\cos(\omega_n T) \exp^{BT} - 1 + \frac{\omega_n \sin(\omega_n T) \exp^{BT}}{B} \right)$$

Where $A = \omega_n \frac{R_s}{Q_n}$ and $B = -\left(\frac{\omega_n}{2Q_n} + i\omega\right)$. The absolute value of Eq. (4) falls off quickly with respect to ω when $\omega \notin \{\omega_n\}$. Therefore each mode can be treated separately and the impedance calculated from a wakefunction truncated at time T , at a resonant frequency ω_n will to a good approximation be given by:

$$\mathcal{Z}_{||}(\omega_n, T) = \frac{A}{B + \omega_n^2/B} \cdot C \quad (5)$$

$\mathcal{Z}_{||}(\omega_n, T)$ can also be calculated using a truncated wake-field using the equation below:

$$\mathcal{Z}_{||}(\omega, T) = -\frac{\int_{-\infty}^{\infty} \mathcal{W}_{||T}(\tau) \exp(-i\omega\tau) d\tau}{\int_{-\infty}^{\infty} \lambda(t) \exp(-i\omega\tau) d\tau} \quad (6)$$

Where $\mathcal{W}_{||T}(t)$ is the wakefield truncated at time T and $\lambda(t)$ is the charge distribution of the exciting bunch.

For a wakefield which has been obtained with a maximum simulation time T_{max} it is trivial to obtain wakefields which

have been truncated at time $T < T_{max}$. Therefore, for each mode, Eq. (6) can be used to obtain $Z_{||}(\omega_n, T)$ for a range of times T up to T_{max} . Q_n and $\frac{R_s}{Q_n}$ can then be obtained from a two parameter least-squares fit of Eq. (5). Once Q_n and $\frac{R_s}{Q_n}$ have been obtained for each mode, the wakefunction can be calculated from Eq. (1) which can then be fed into Eq. (2). Therefore this method allows the converged impedance spectrum to be estimated from a partially decayed wakefield.

WAKEFIELD SIMULATION

CST Particle Studio was used to perform a 1 km wakefield simulation on the pillbox cavity shown in Fig. 1. A wall conductivity of 10^6 S/m, was used to give low Q factors allowing the full wakefield to be calculated and the results of the method to be validated. Analytic beam injection method and the indirect test beams method [5] were used. The standard deviation of the charge distribution was set to 15 mm. The resulting wakefield is shown in Fig. 2.

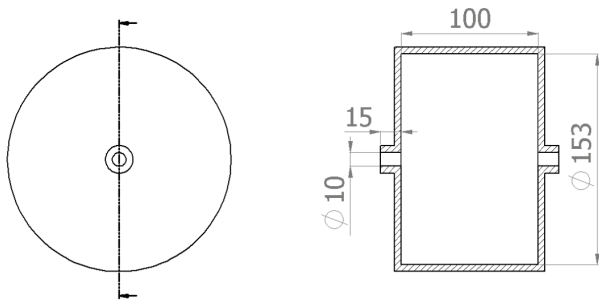

Figure 1: Dimensioned schematic of the wall geometry for the pillbox cavity used for proof of principle tests.

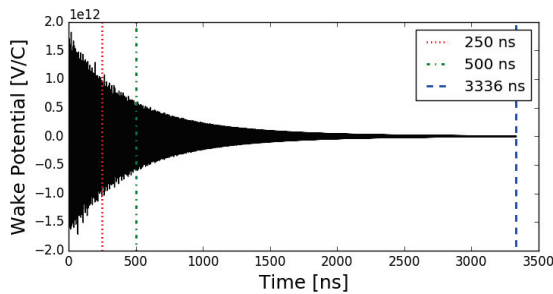

Figure 2: Wakefield response from initial simulation.

IMPEDANCE CONVERGENCE ANALYSIS AND EXTRAPOLATION METHOD

Figure 3 shows the impedance spectrum upto 6 GHz calculated using Eq. (6) for the wakefield truncated at different times T . Fig. 4 shows the peak impedance against wake truncation time T for the first 3 longitudinal modes.

The least-squares method was used to do a two parameter fit of Eq. (5) to the data shown in Fig. 4 (note in Fig. 4, 50 points are shown whereas in reality 1000 points were used). Fig. 6 shows the values of $\frac{R_s}{Q}$ and Q obtained against

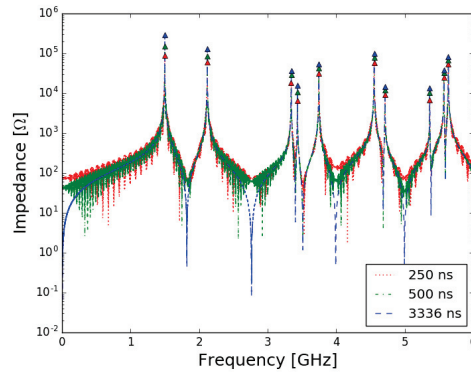

Figure 3: Impedance spectrum plots corresponding to 3 lengths of wakefield. Triangles show the peak tracking algorithm used.

time for the first three modes. For example a point at 100 ns represents the fitted values obtained by applying the method to a wakefield truncated at 100 ns. The value of $\frac{R_s}{Q}$ quickly converged towards the literature value of 196Ω [6] for this geometry of cavity.

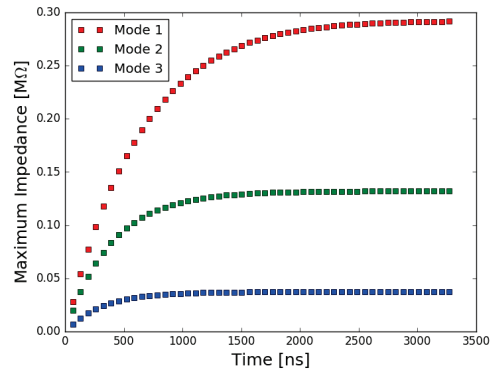

Figure 4: Maximum impedance against length of wake decay used for calculation for the first three modes shown in Fig. 3.

The red dotted line and solid black line in Fig. 5 represent the fully converged and un-converged impedance spectrum obtained from a 3336 ns and 250 ns wakefield respectively. The blue dashed line in Fig. 5 represents the impedance spectrum obtained by applying the method outlined in sec. to a wakefield of 250 ns. It can be seen that this reconstructed impedance spectrum matches the converged impedance spectrum much more closely than the impedance spectrum calculated directly from the truncated wakefield. This is particularly true at the resonant frequencies of the modes.

Figure 7 shows the convergence speed of the peak impedance for the first three modes against the length of wakefield used to make the calculation. The results obtained by applying the method presented in this paper and without applying the method are shown as solid lines and dashed lines respectively.

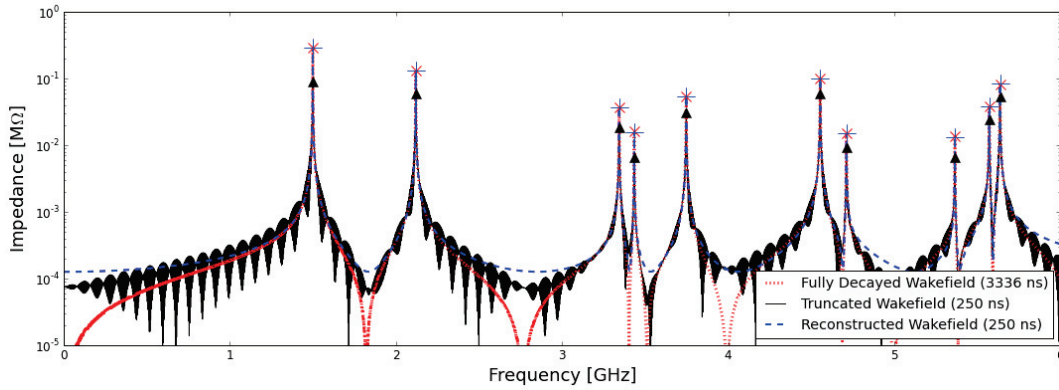

Figure 5: The impedance spectrum derived from the fully decayed wakefield is shown in red. The impedance derived directly from the same wakefield truncated at 250 ns is shown in black. The impedance derived from the method presented in this paper applied to the wakefield truncated at 250 ns is shown in blue.

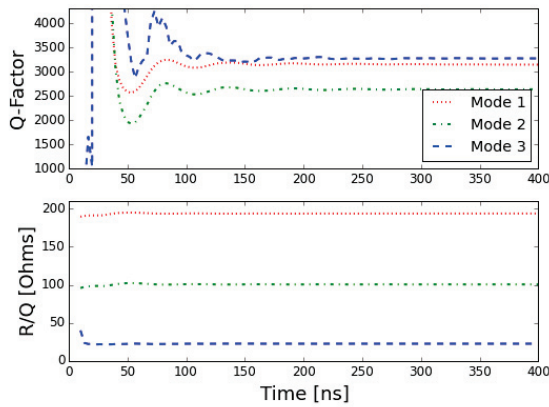

Figure 6: Values of R/Q and Q obtained for three modes by the method here presented applied to wakefields of different lengths T .

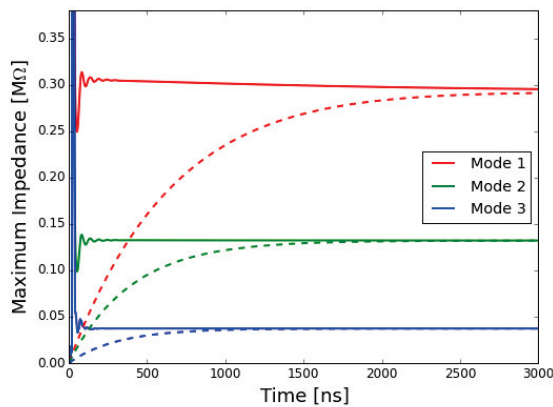

Figure 7: Comparison of Impedance convergence with (solid lines) and without (dashed lines) applying the method presented in this paper, for the first 3 modes.

SUMMARY

The method presented in this paper allowed the peak impedances of all of the 10 modes studied to be calculated to within 5% of the converged value within 149 ns compared to 1735 ns without applying the method. As wakefield simulations are linear with time therefore, by applying this method, the same accuracy of results can be obtained with ≈ 12 times less simulation time. Future work will verify the method for higher Q and more complex cavities and extend the method to transverse impedance.

REFERENCES

- [1] G. Burt, R. M. Jones and A. Dexter *et al.*, “Analysis of Damping Requirements for Dipole Wake-Fields in RF Crab Cavities”, *IEEE Transactions on Nuclear Science*, vol. 54, pp. 1728–1734, 2007.
- [2] P. Ambattu *et al.*, “Analysis and control of wakefields in X-band crab cavities for Compact Linear Collider”, *Nucl. Instr. Meth.*, vol. 657, pp. 27–37, 2011.
- [3] CST Particle Studio, <http://www.cst.com>
- [4] B. Zotter and S. Kheifets, “Loss Factors and Effective Impedances”, in *Impedances and Wakes in High-Energy Particle Accelerators*: World Scientific Publishing, 1998, pp. 97–132.
- [5] T. Weiland and R. Wanzenberg, “Wake Fields and Impedances”, in *CCAS-CAT-CERN Accelerator School*, Indore, India, November 1993, pp. 140–180.
- [6] H. Padamsee, *RF Superconductivity for Accelerators*. Cornell University, NY, USA: John Wiley & Sons, 1998.

- Pre-Release Snapshot 19-May-2017 10:10

Copyright © 2017 CC-BY-3.0 and by the respective authors